

Date		5.6.2015 r.		Tomika metal AG		EKM GmbH		Power supply		=	
Ed.		VASIL		Vinificator BM 30,5m3.Control Temperature and Pump-cycle						+	
Appr				Replacement of		Replaced by				JN-115.156.01	
Modification	Date	Name	Original							Page	2
										Page	

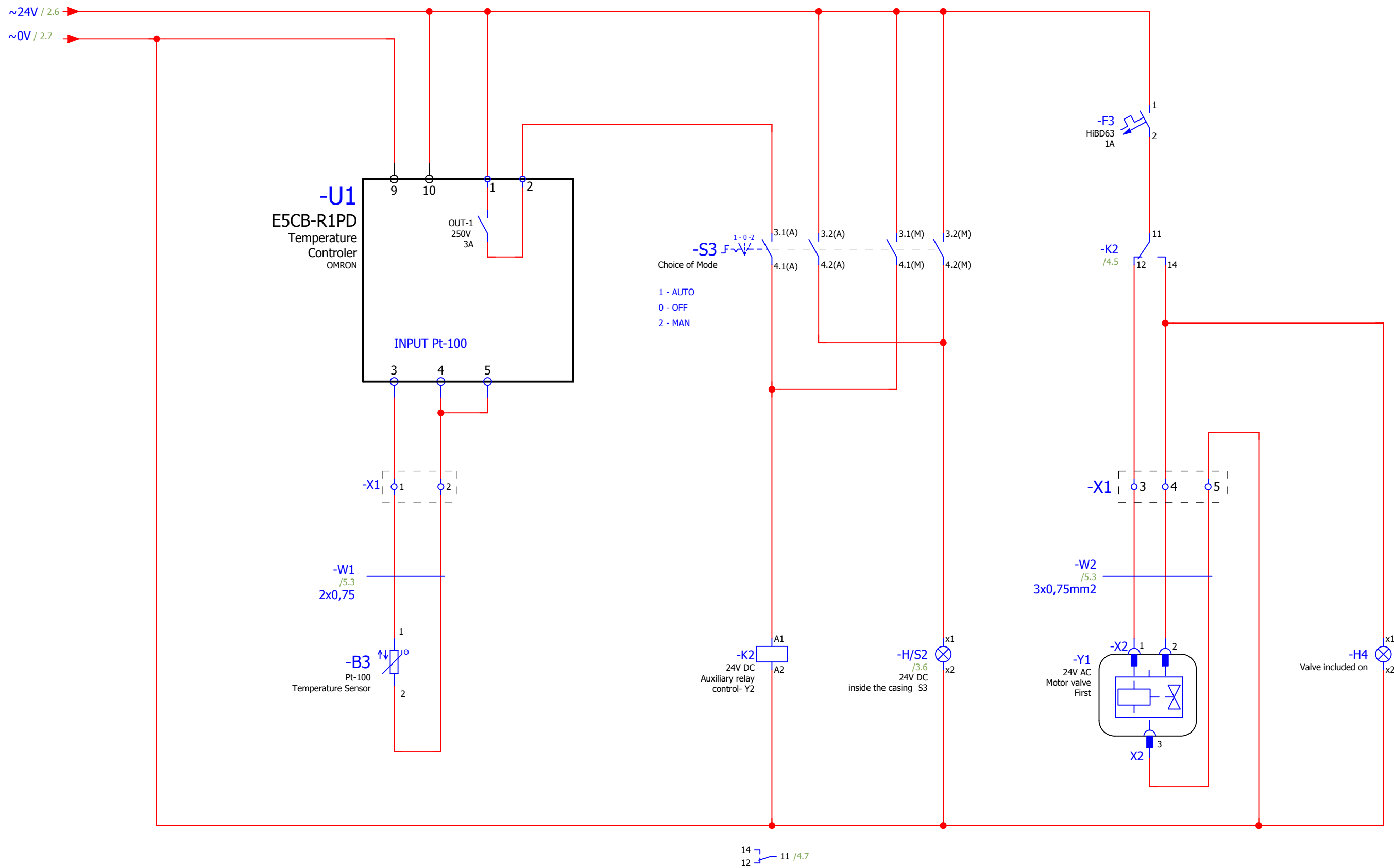

		Date	5.6.2015 r.	Tomika metal AG		EKM GmbH		Control Temperature		=	
		Ed.	VASIL							+	
		Appr		Vinificator BM 30,5m3.Control Temperature and Pump-cycle						JN-115.156.01	
Modification	Date	Name	Original	Replacement of	Replaced by					Page	4
										Page	

