

SC / SU Series Standard Cylinder



JELPC[®]

JELPC

— 44444444 —
Automatic

Stroke

Bore	Standard Stroke																Max. Stroke	Allowable Stroke					
32	25	50	75	80	100	125	150	160	175	200	250	300	350	400	450	500	1000	2000					
40	25	50	75	80	100	125	150	160	175	200	250	300	350	400	450	500	600	700	800	1200	2000		
50	25	50	75	80	100	125	150	160	175	200	250	300	350	400	450	500	600	700	800	900	1000	1200	2000
63	25	50	75	80	100	125	150	160	175	200	250	300	350	400	450	500	600	700	800	900	1000	1500	2000
80	25	50	75	80	100	125	150	160	175	200	250	300	350	400	450	500	600	700	800	900	1000	1500	2000
100	25	50	75	80	100	125	150	160	175	200	250	300	350	400	450	500	600	700	800	900	1000	1500	2000
125	25	50	75	80	100	125	150	160	175	200	250	300	350	400	450	500	600	700	800	900	1000	1500	2000
160	25	50	75	80	100	125	150	160	175	200	250	300	350	400	450	500	600	700	800	900	1000	1500	2000
200	25	50	75	80	100	125	150	160	175	200	250	300	350	400	450	500	600	700	800	900	1000	1500	2000
250	25	50	75	80	100	125	150	160	175	200	250	300	350	400	450	500	600	700	800	900	1000	1500	2000
320	25	50	75	80	100	125	150	160	175	200	250	300	350	400	450	500	600	700	800	900	1000	1500	2000

Internal Structure

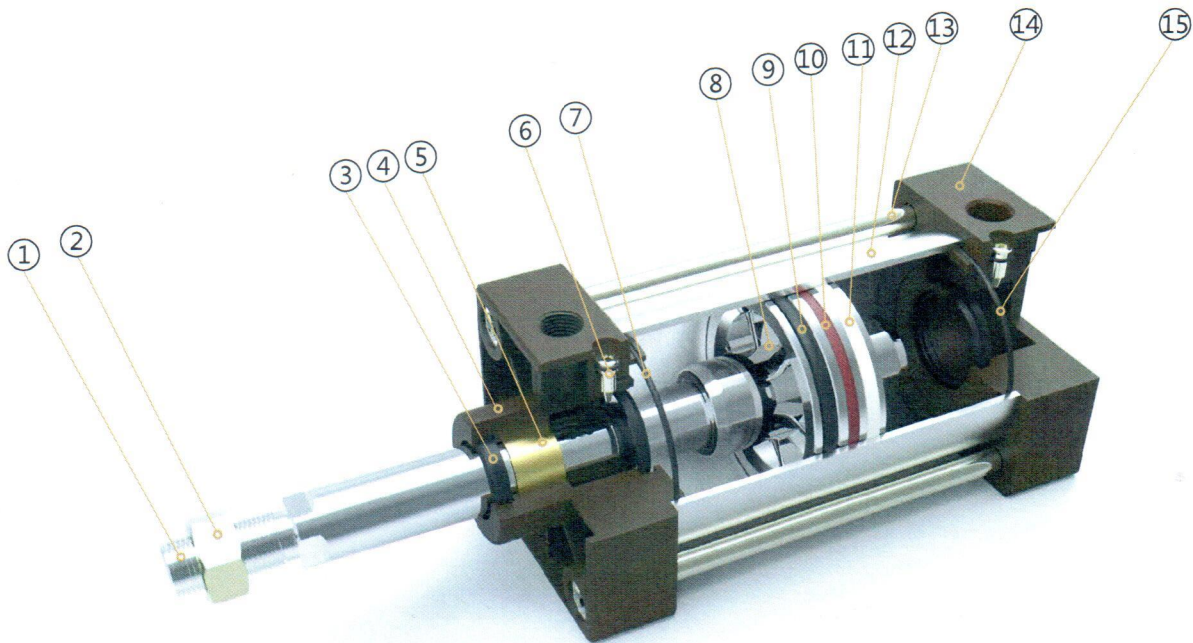

Parts

Number	Name	Number	Name
1	Piston rod	9	Piston seal
2	Hexagon nut	10	Magnet
3	Shaft seal	11	Anti-friction ring
4	Front cover	12	Barrel
5	Copper tube	13	Pull rod
6	Cushion adjust screw	14	Back cover
7	Cushion seal	15	O ring
8	Piston		

- Cylinder
- Sizing
- SI
- SI A.
- SIB
- SQ
- DNT
- SC / SU**
- SCT
- SC A.
- SL
- DN
- DSN
- DN/DSNA
- MA
- MAC
- MA/MACA
- MAL
- MALC
- MAL/MALCA
- SDA
- CQ2
- TCQ2
- ADN
- TADN
- PPRM
- CJ2
- CDU
- TN
- CXS
- MGP
- MSQ